

⚠ Safety Cautions

- Read the entire "Instruction Manual" carefully for important information about safety, handling, installation, operation, maintenance, and parts replacements.
- This equipment is designed and built in accordance with applicable safety standard in effect on the date of manufacture. Unauthorized modifications will void warranty and can result in severe injury, death and property damage. Do not make any modifications to the equipment.
- Only qualified persons are to install, operate or service this equipment according to all applicable codes and established safety practices.
- Use only genuine Toshiba replacement parts and accessories. Improper components could cause the equipment malfunction.
- Do not install this equipment in areas where unusual service conditions exist. Using this equipment in other than usual service conditions can result in equipment failure.
- Do not exceed the ratings specified on the equipment nameplate or system accessories. Underrated equipment can fail during operation causing fire, explosion, severe injury, death, and property damage.

**HIGH-VOLTAGE
VACUUM CONTACTORS**



CV-6GAL/6HAL
7.2kV-200/400A-6.3kA

TOSHIBA

TOSHIBA CORPORATION

TRANSMISSION DISTRIBUTION & INDUSTRIAL SERVICES COMPANY

1-1, SHIBAURA 1-CHOME, MINATO-KU, TOKYO 105-8001, JAPAN
PHONE +81-3-3457-4898 FAX +81-3-5444-9169

<http://www3.toshiba.co.jp/sic/english/swgr/products.htm>

● The data given in this catalog are subject to change without notice.

VACUUM CONTACTORS

Since the introduction of the first Vacuum Interrupter in 1962, Toshiba has been continuously improving and developing Vacuum Technology.

Over 3 millions Vacuum interrupters have been produced for various types of vacuum apparatus such as contactors, circuit breakers and switches which are now widely used as result of their outstanding performance.

Toshiba has become a leading Japanese manufacturer that has attained a record exceeding 230 thousands Low and High voltage Vacuum Contactors produced.

Consistent with its dedication to the most advanced vacuum technology, Toshiba offers new series of High-voltage vacuum contactors.

By adopting an electronics controlled circuit and being designed compactly to ensure reliability, handling ease and safety, the new series of High-voltage Vacuum Contactors are suitable for Motor starters, Transformer feeders and Capacitor switching applications.



Class NK certificate (Marine application)

FEATURES

Compact and Lightweight

Compact and slim design contactors can be applied to either two-tier motor starters or slim starters per IEC 60470 (2000). The Contactors CV-6GA(L) and CV-6HA(L) have the same outline and mounting dimensions, as well as dual voltage ratings (3.6/7.2kV).

Low Power Consumption

The control device adopts an electronic circuit, the control voltage either AC or DC can be easily changed by switches in the circuit board without changing the coil and/or other parts. Since the economizing resistors are eliminated, the power consumption in holding condition has been reduced.

Excellent Breaking Performance

Since the higher interrupting capacity and short-time withstand capability, Toshiba Vacuum Contactors are appropriate to fuse combination for large capacity load, and to high-speed breaking.

No Surge Protection Required

Special main contact materials minimize chopping current. No surge suppressor/arrester is required except for special applications.

Conformity to Industrial Standard

Conforming to latest international standards such as IEC, BS, AS and JEM, being certified by class NK and TÜV, Toshiba Vacuum Contactors can be used widely all over the world.

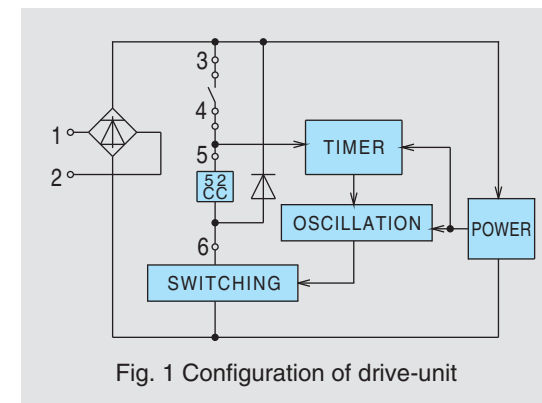

Fig. 1 Configuration of drive-unit



TÜV certificate

Series

	Ratings	Type	Operating mechanism	Application	Standard	
Standard	7.2/3.6kV	200A — 6.3kA	CV-6GA — Non-Latched Type	General	IEC, JEM, Class NK	
		400A — 6.3kA	CV-6GAL — Latched Type	General		
	12kV	400A — 8.0kA	CV-6HA — Non-Latched Type	General		IEC
			CV-6HAL — Latched Type	General		
		400A — 5.0kA	CV-6KA1 — Non-Latched Type	Capacitor		
			CV-6KAL1 — Latched Type	Capacitor		
	15/12kV	400A — 4.0/5.0kA	CV-10HB — Non-Latched Type	Capacitor		IEC, NEMA
			CV-10HBL — Latched Type	Capacitor		
		400A — 4.0/5.0kA	CV-10HA — Non-Latched Type	Motor/Transformer		
			CV-10HAL — Latched Type	Motor/Transformer		
Special Main Terminals	7.2/3.6kV	400A — 6.3kA	CV-6HA-2 — Non-Latched Type	General	IEC, JEM	
		400A — 6.3kA	CV-6HAL-2 — Latched Type	General		
	12kV	400A — 5.0kA	CV-10HB-1 — Non-Latched Type	Capacitor	IEC	
			CV-10HBL-1 — Latched Type	Capacitor		
	15/12kV	400A — 4.0/5.0kA	CV-10HA-1 — Non-Latched Type	Motor/Transformer	IEC, NEMA	
			CV-10HAL-1 — Latched Type	Motor/Transformer		



CV-10HA(L)
15/12kV-400A-4/5kA

CV-10HB(L)
12kV-400A-5kA



CV-6KA1
7.2kV-720A-8kA



(Rear side of CV-10HA)

RATINGS AND SPECIFICATIONS

3.6kV/7.2kV High-voltage Vacuum Contactors

Type		CV			
Form	Standard	6GA	6HA	6GAL	6HAL
	Upper front terminal	-	6HA-2	-	6HAL-2
Operating Mechanism		Non-Latched		Latched	
Rated Voltage (U_r)		3.6/7.2kV			
Rated Operational Current (I_e)		200A	400A	200A	400A
Thermal Current (I_{th})		300A	450A	300A	450A
Rated Frequency		50/60Hz			
Rated Short-time Withstand Current (I_k)		6300A - 1s	6300A - 2s	6300A - 1s	6300A - 2s
Rated peak Withstand Current (I_p)		15.8kA			
Short-circuit Making and Breaking Current (Duty)		6300A "O" - 3min. - "CO" - 3min. - "CO"			
Making Current (100times) AC4		2000A	4000A	2000A	4000A
Breaking Current (25times) AC4		1600A	3200A	1600A	3200A
Withstand Overload Current 6 times of I_e - 30s 15 times of I_e - 1s		1200A-30s	2400A-30s	1200A-30s	2400A-30s
		4000A-4s	4000A-12s	4000A-4s	4000A-12s
		6300A-1s	6300A-2s	6300A-1s	6300A-2s
Coordination with Current-limiting Fuses Cut-off Current (Peak)		Prospective Short-circuit Current 40kA			
Rated Insulation Level	Power Frequency Withstand Voltage	22kV-1min. *1			
	Impulse Withstand voltage	60kV			
Switching Frequency		1200 operating cycles/hr		300 operating cycles/hr	
Endurance	Mechanical Life	2.5 million operations		0.25 million operations	
	Electrical Life (AC3)	0.25 million operations		0.25 million operations	
Rated Control Voltage	Closing	100-110, 115-120, 200-220, 230-240VAC / 100-110, 200-220VDC			
	Tripping	24, 32, 48, 100-110, 200-220VDC			
Allowable Control Voltage Fluctuation		85% to 110% of the rated control voltage			
Operating Current (at 100V)	Closing	4.5A (Peak)			
	Holding/Tripping	0.1A (Average)		4.0A (Peak)	
Closing Time		65 - 80ms			
Opening Time		20 - 30ms			
Ratings of Auxiliary Contact	Contact arrangement	3NO-3NC		2NO-2NC	
	Operational voltage	Max. 480V, Min. 48V			
	Thermal Current	10A			
	AC Capacity	700VA (PF. 0.35)			
	DC Capacity	60W (L/R 150ms)			
Application Condition	Installation	Floor Mount Vertical Installation			
	Altitude	1000m or lower			
	Ambient air temperature	-5 to 40°C			
	Relative humidity	45 to 85%			
	Vibration	Max. 20Hz 1G			
	Shock	Max. 30G			
Maximum Load	Motor (kW)	750/1500	1500/3000	750/1500	1500/3000
	Transformer (kVA)	1000/2000	2000/4000	1000/2000	2000/4000
	Capacitor (kvar)	1000/2000	2000/2000	1000/2000	2000/2000
Weight		19.0kg	19.5kg	19.5kg	20.0kg
Standard *2		IEC60470 (2000)			
		JEM1167 (1990)			

*1 : Special withstand voltage (32kV-1min.) will be available by request.

*2 : CE marking can be available by request.

RATINGS AND SPECIFICATIONS

3.6kV/7.2kV High-voltage Vacuum Contactors

Type		CV	
Form		6KA1	6KAL1
Operating Mechanism		Non-Latched	Latched
Rated Voltage (U_r)		3.6/7.2kV	
Rated Operational Current (I_e)		720A	720A
Thermal Current (I_{th})		800A	800A
Rated Frequency		50/60Hz	
Rated Short-time Withstand Current (I_k)		8000A - 1s	
Rated peak Withstand Current (I_p)		20kA	
Short-circuit Making and Breaking Current (Duty)		8000A "O" - 3min. - "CO" - 3min. - "CO"	
Making Current (100times) AC4		7200A	7200A
Breaking Current (25times) AC4		5760A	5760A
Withstand Overload Current 6 times of I_e - 30s 15 times of I_e - 1s		4320A-30s	4320A-30s
		10800A-1s	10800A-1s
Coordination with Current-limiting Fuses Cut-off Current (Peak)		Prospective Short-circuit Current 40kA	
Rated Insulation Level	Power Frequency Withstand Voltage	22kV - 1 min. *1	
	Impulse Withstand voltage	60kV	
Switching Frequency		600 operating cycles/hr	300 operating cycles/hr
Endurance	Mechanical Life	1.0 million operations	0.2 million operations
	Electrical Life (AC3)	0.2 million operations	0.2 million operations
Rated Control Voltage	Closing	100-240VAC / 100-220VDC	
	Tripping	-	100-110, 200-220VDC
Allowable Control Voltage Fluctuation		85% to 110% of the rated control voltage	
Operating Current (at 100V)	Closing	7.5A (Peak)	
	Holding/Tripping	0.19A (Average)	4.0A (Peak)
Closing Time		80 - 100ms	
Opening Time		55 - 65ms	
Ratings of Auxiliary Contact	Contact arrangement	3NO-3NC	2NO-2NC
	Operational voltage	Max. 480V, Min. 48V	
	Thermal Current	10A	
	AC Capacity	700VA (PF. 0.35)	
	DC Capacity	60W (L/R 150ms)	
Application Condition	Installation	Floor Mount Vertical Installation	
	Altitude	1000m or lower	
	Ambient air temperature	-5 to 40°C	
	Relative humidity	45 to 85%	
	Vibration	Max. 20Hz 1G	
	Shock	Max. 30G	
	Maximum Load	Motor	2500/5000kW
Transformer		3500/7000kVA	
Capacitor		2000/2000kvar	
Weight		27kg	28kg
Standard		IEC60470 (2000)	
		JEM1167 (1990)	

*1 : Special withstand voltage (32kV-1min.) will be available by request.

RATINGS AND SPECIFICATIONS

12kV/15kV High-voltage Vacuum Contactors

Type		CV			
From	Standard	10HA	10HAL	10HB	10HBL
	Vertical terminals	10HA-1	10HAL-1	10HB-1	10HBL-1
Operating Mechanism		Non-Latched	Latched	Non-Latched	Latched
Rated Voltage (U_r)		12/15kV		12kV	
Rated Operational Current (I_e)		400A		400A	
Thermal Current (I_{th})		450A		450A	
Rated Frequency		50/60Hz			
Rated Short-time Withstand Current (I_k)		5000A - 1s		5000A - 1s	
Rated peak Withstand Current (I_p)		12.5kA		12.5kA	
Short-circuit Making and Breaking Current (Duty)		5000/4000A		5000A	
Making Current (100 times) AC4		4000A		4000A	
Breaking Current (25 times) AC4		3200A		3200A	
Withstand Overload Current		2400A-30s		2400A-30s	
6 times of I_e - 30s		8000A-1s		8000A-1s	
15 times of I_e - 1s					
Coordination with Current-limiting Fuses		Prospective Short-circuit Current 50kA			
Cut-off Current (Peak)		36kA			
Rated Insulation Level	Power Frequency Withstand Voltage	28kV - 1 min. *1			
	Impulse Withstand voltage	75kV			
Switching Frequency		300 op./hr	120 op./hr	300 op./hr	120 op./hr
Endurance	Mechanical Life	0.25 mill.	0.25 mill.	0.25 mill.	0.25 mill.
	Electrical Life (AC3)	0.10 mill.	0.10 mill.	0.10 mill.	0.10 mill.
Rated Control Voltage	Closing	100-240VAC / 100-220VDC			
	Tripping	100-110, 200/220VDC			
Allowable Control Voltage Fluctuation		85% to 110% of the rated control voltage			
Operating Current (at 100V)	Closing	6.0A (Peak)			
	Holding/Tripping	0.13A (Av.)	4.0A (Peak)	0.13A (Av.)	4.0A (Peak)
Closing Time		120-145ms	120-145ms	120-145ms	120-145ms
Opening Time		80-90ms	30-40ms	80-90ms	30-40ms
Ratings of Auxiliary Contact	Contact arrangement	4NO-2NC	2NO-1NC	4NO-2NC	2NO-1NC
	Operational voltage	Max. 480V, Min. 48V			
	Thermal Current	10A			
	AC Capacity	700VA (PF. 0.35)			
	DC Capacity	60W (L/R 150ms)			
Application Condition	Installation	Floor Mount Vertical Installation			
	Altitude	1000m or lower			
	Ambient air temperature	-5 to 40°C			
	Relative humidity	45 to 85%			
	Vibration	Max. 20Hz 1G			
	Shock	Max. 30G			
Maximum Load	Motor	3500kW		-	
	Transformer	4500kVA		-	
	Capacitor	-		5000kvar	
Weight		40kg	41kg	40kg	41kg
Standard		IEC60470 (2000)			

*1 : Special withstand voltage (42kV-1min.) will be available by request.

ACCESSORIES PROVIDED AS STANDARD

○ : Supplied — : Not supplied

Name of parts	CV-6GA/6HA		CV-6KA1		CV-10HA/10HB		Remarks
	Non-Latched	Latched	Non-Latched	Latched	Non-Latched	Latched	
Wipe gauge	○	○	○	○	○	○	For checking contact wear
Trip rod	—	○	—	○	—	○	For latched type only
Control wire	—	—	—	—	○	○	With plug (1.25mm ² X 1m)

● Wipe gauge

The wipe gauge can be used for checking contact wear of vacuum interrupters. Refer to the instruction manual for using this gauge.

● Trip rod

The trip rod may be used for manual tripping for latched contactor and combination unit, however this operation shall be maintenance purpose or emergency case only.

● Control wire

The control wire with plug is provided on CV-10 series contactor, however the additional wire will be available on request.

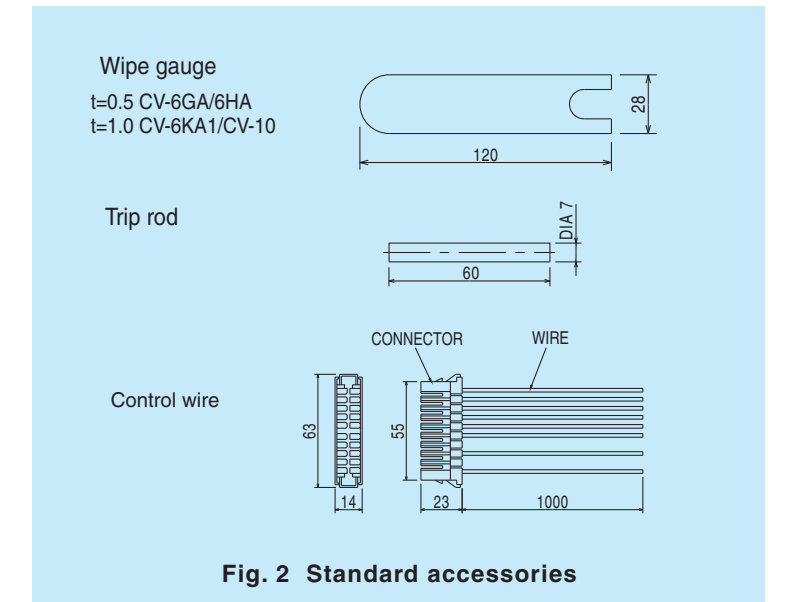

Fig. 2 Standard accessories

OPTIONAL ACCESSORIES UPON REQUEST

△ : Supplied — : Not supplied

Name of parts	CV-6GA/6HA		CV-6KA1		CV-10HA/10HB		Remarks
	Non-Latched	Latched	Non-Latched	Latched	Non-Latched	Latched	
Capacitor trip device	LC9	—	△	—	△	—	For Latched type
	LC10	—	△	—	△	—	
	CIT-10Q	—	△	—	△	—	
CR Surge suppressor	△	△	△	△	△	△	NV60K304T1, NV95K304T1 (See Page 13)
Mechanical interlock	△	△	△	△	—	—	(See Fig. 9)

● Capacitor trip device

The capacitor trip device will be used for latched contactor when DC power source is not available. The device charges from AC power, and supplies DC power to the trip coil at trip command. The alarm contact is provided on CIT-10Q.

● Surge suppressor

The three phase type NV60K304T1 for 3.6/7.2kV and NVK95K304T1 for 12/15kV are available.

● Mechanical interlock

The mechanical interlock shall be used in the reversing starter to prevent mechanically from closing the forward and reverse contactors simultaneously.

The following vertical pitch interlocks are available for contactors.
 Vertical pitch 450 mm and 550mm for CV-6GA(L)/CV-6HA(L)
 Vertical pitch 600mm for CV-6KA(L)1

3.6/7.2kV 200A/400A 6.3kA Vacuum Contactors

OUTLINE DIMENSIONS

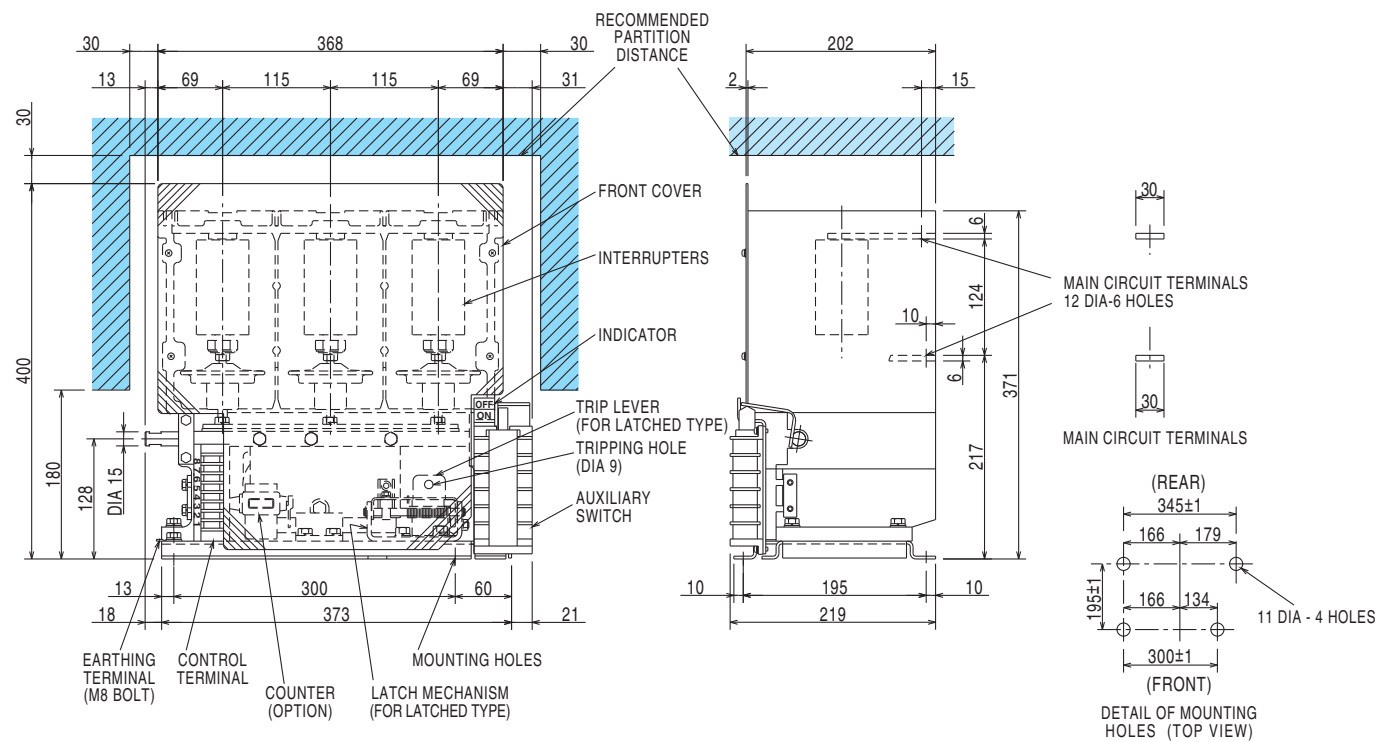

Fig. 3 Types CV-6GA(L)/CV-6HA(L)

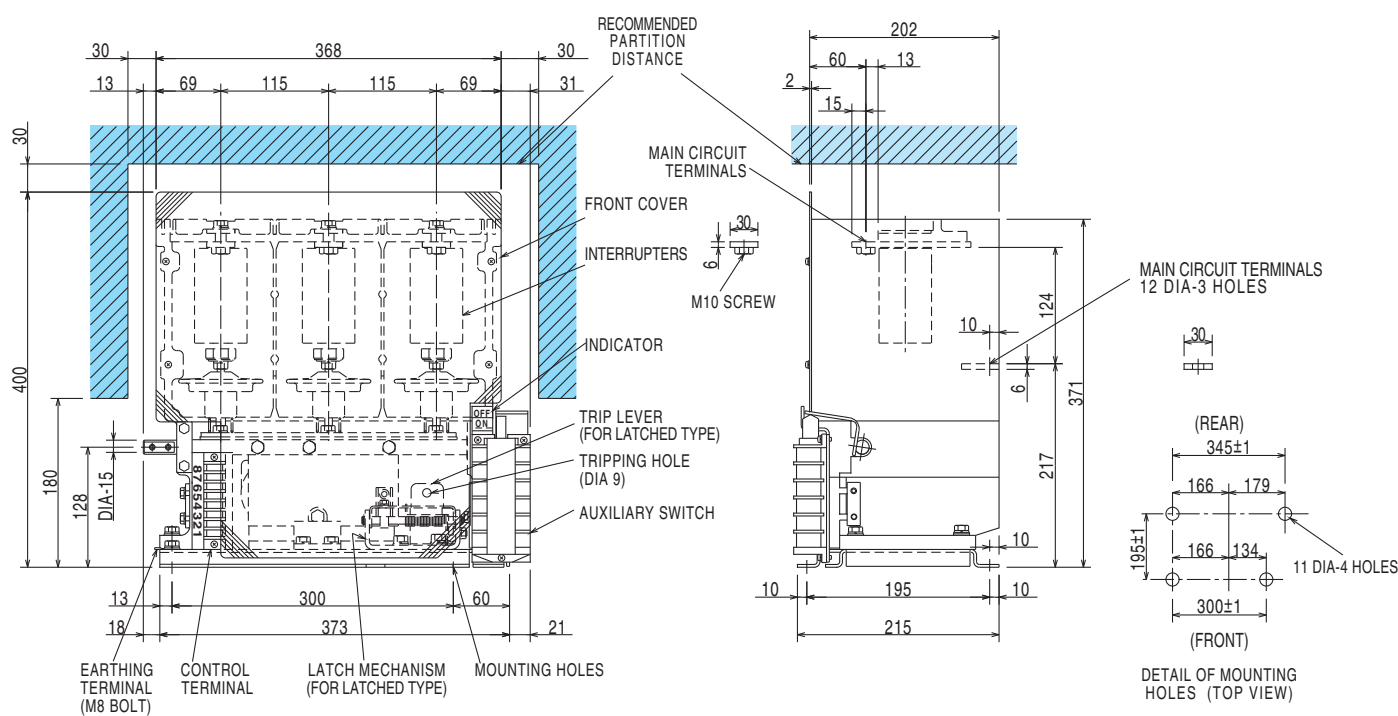

Fig. 4 Types CV-6HA(L)-2

OPERATING CIRCUITS

Non-Latched type High-Voltage Vacuum Contactors

The typical operating circuit is shown in Fig. 5 indicating type CV-6GA/6HA contactor. Make sure to use the "NO" contacts of quick operating relay (4) self-holding circuit. Do not use the "NO" auxiliary contacts of vacuum contactor, this may cause the welding of main contacts when the start (ON) button is pushed incompletely. (refer to the marked 1 in figure) Make sure to switch the closing coil on DC side. Should the coil be switched on AC side, a discharging circuit will be formed by rectifiers against coil, resulting in prolonged opening time. (refer to the marked 2 in figure)

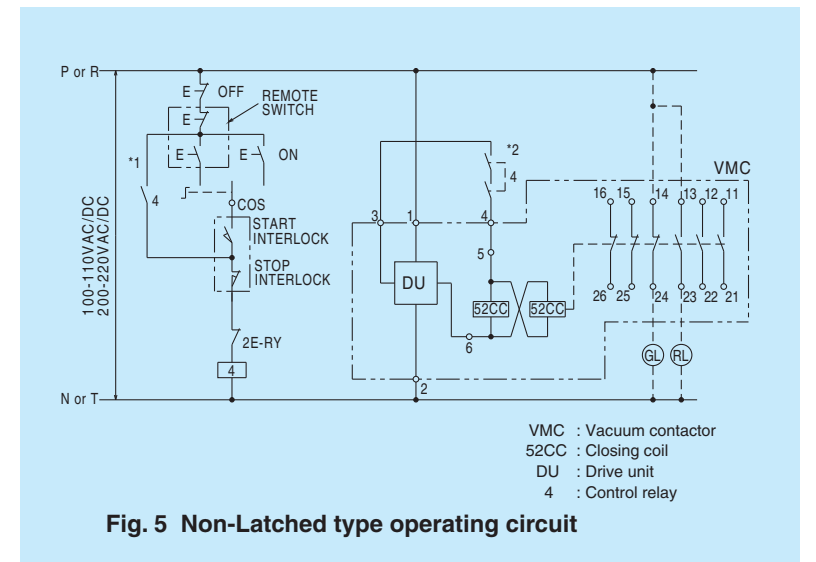

Fig. 5 Non-Latched type operating circuit

Latched type High-Voltage Vacuum Contactors

The typical operating circuits are shown in Fig. 6 and Fig. 7 indicating type CV-6GAL/6HAL contactor. The electrical trip free circuit must be furnished in control circuit. (outside of contactor) A stable DC power source such as battery is recommended for control circuit. If the DC power source is not available, employ the AC closing and capacitor trip device (CTD) for tripping. Make sure to use the "NO" auxiliary contacts (11-21) of vacuum contactor in trip circuit, and "Late Opening NC" auxiliary contacts (16-26) of vacuum contactor for control relay circuit.

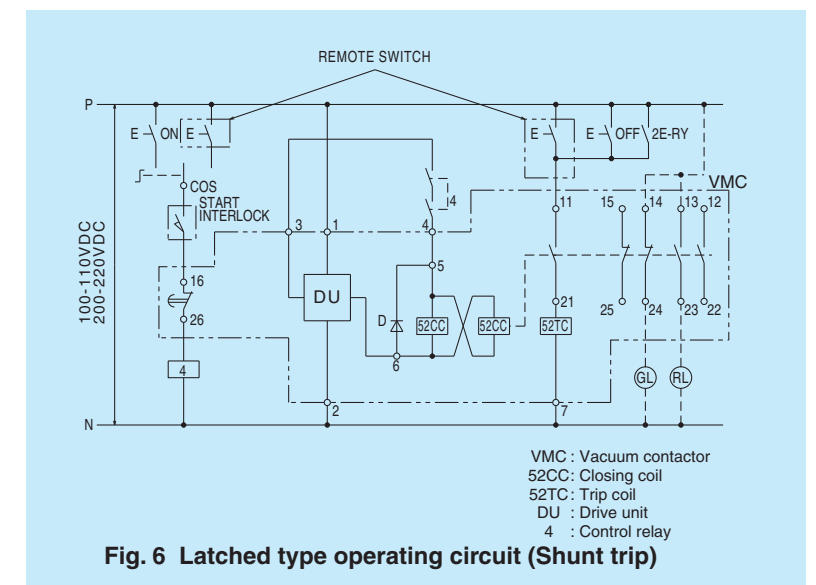

Fig. 6 Latched type operating circuit (Shunt trip)

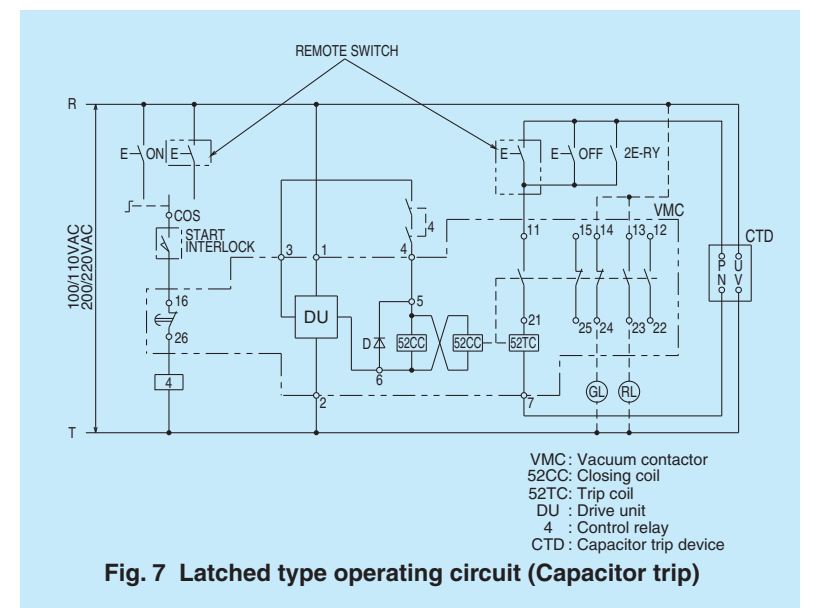

Fig. 7 Latched type operating circuit (Capacitor trip)

3.6/7.2kV 720A 8.0kA Vacuum Contactors

OUTLINE DIMENSIONS

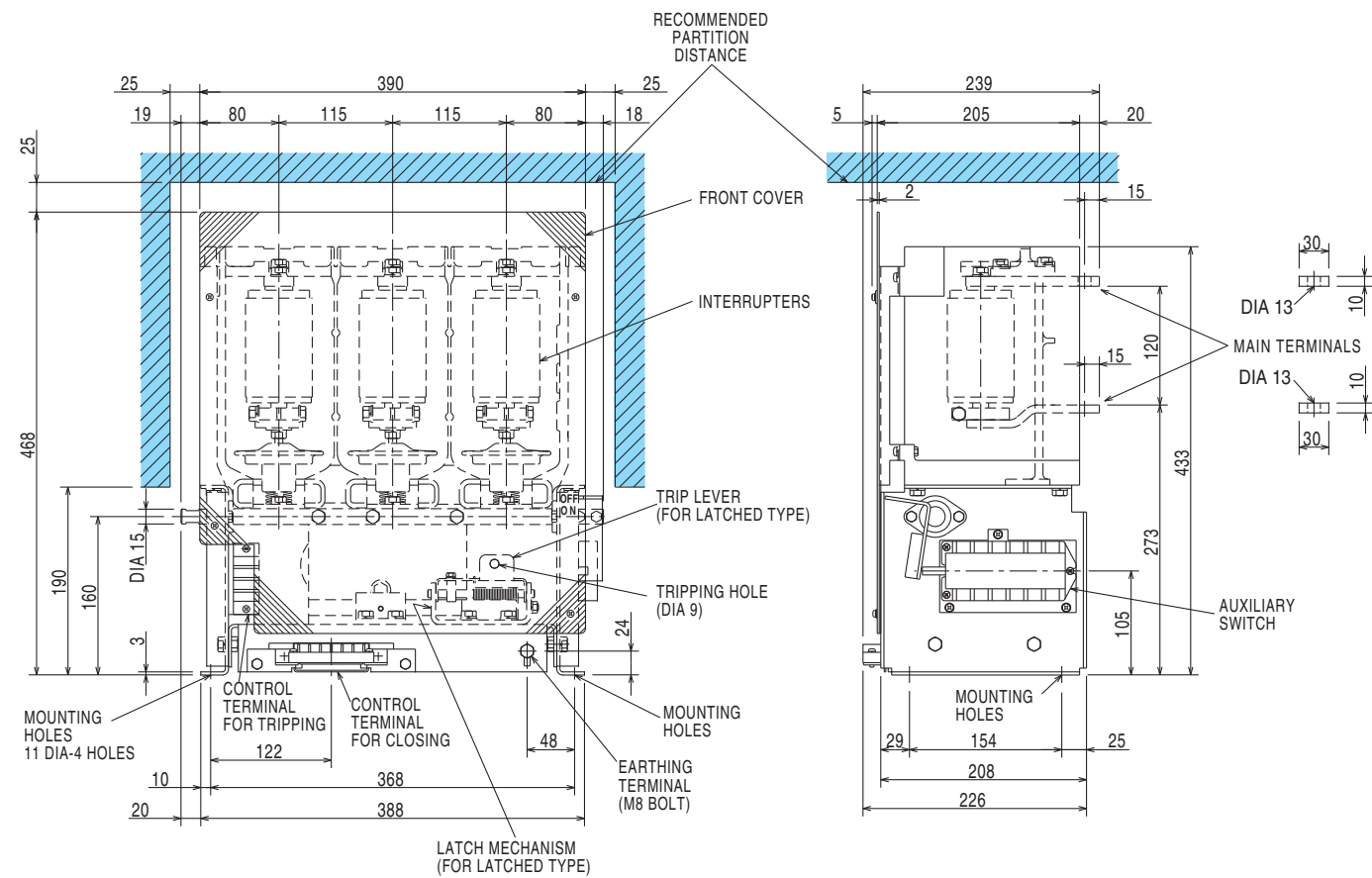

Fig. 8 Types CV-6KA1/CV-6KAL1

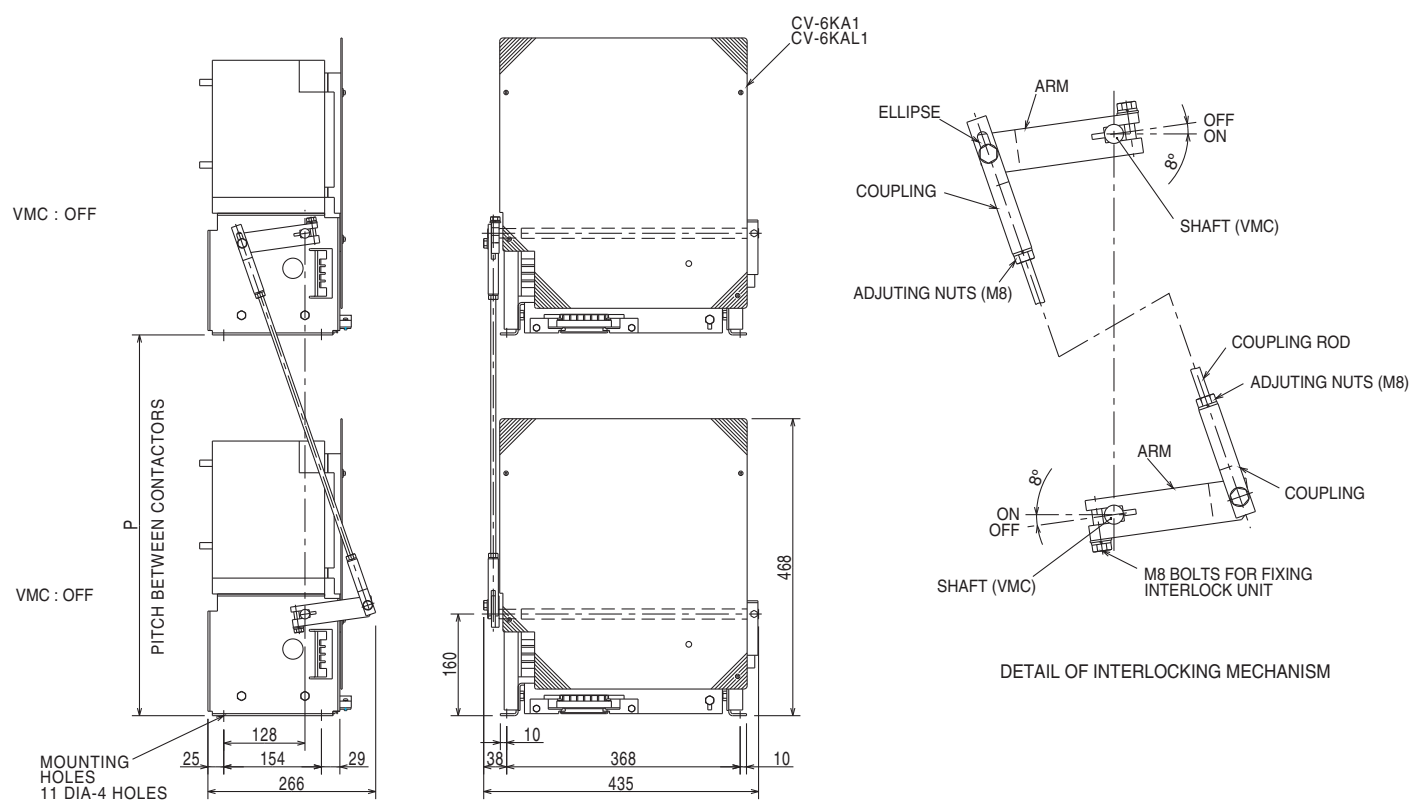

Fig. 9 Mechanical Interlock on CV-6KA(L)1

OPERATING CIRCUITS

Non-Latched type High-Voltage Vacuum Contactors

The typical operating circuit is shown in Fig. 10 indicating type CV-6KA1 contactor.

Make sure to use the "NO" contacts of quick operating relay (4) self-holding circuit. Do not use the "NO" auxiliary contacts of vacuum contactor, this may cause the welding of main contacts when the start (ON) button is pushed incompletely. (refer to the marked 1 in figure)

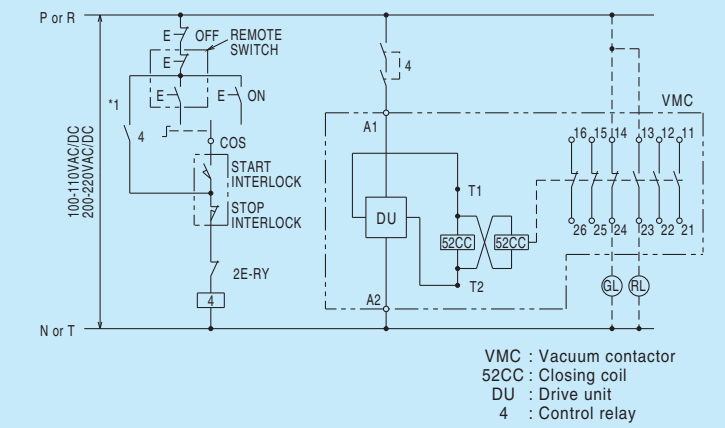

Fig. 10 Non-Latched type operating circuit

Latched type High-Voltage Vacuum Contactors

The typical operating circuits are shown in Fig. 10 and Fig. 11 specifying type CV-6KAL1 contactor.

The electrical trip free circuit must be furnished in control circuit. (outside of contactor)

A stable DC power source such as battery is recommended for control circuit. If the DC power source is not available, employ the AC closing and capacitor trip device (CTD) for tripping.

Make sure to use the "NO" auxiliary contacts (11-21) of vacuum contactor in trip circuit, and "NC" auxiliary contacts (16-26) of vacuum contactor for control relay circuit.

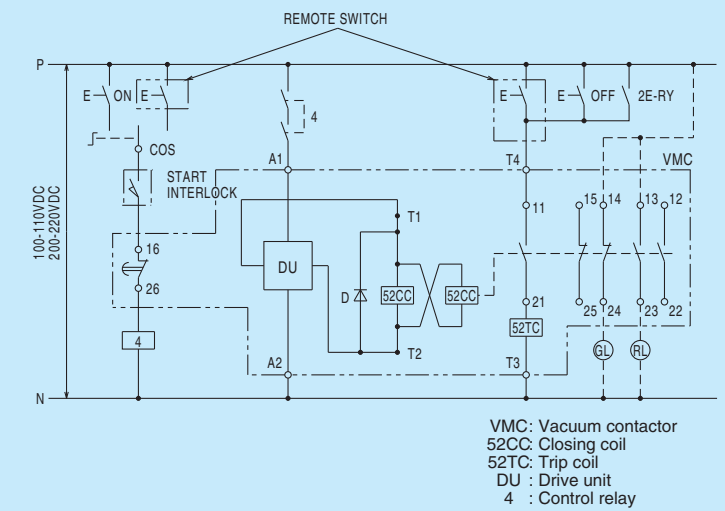

Fig. 11 Latched type operating circuit (Shunt trip)

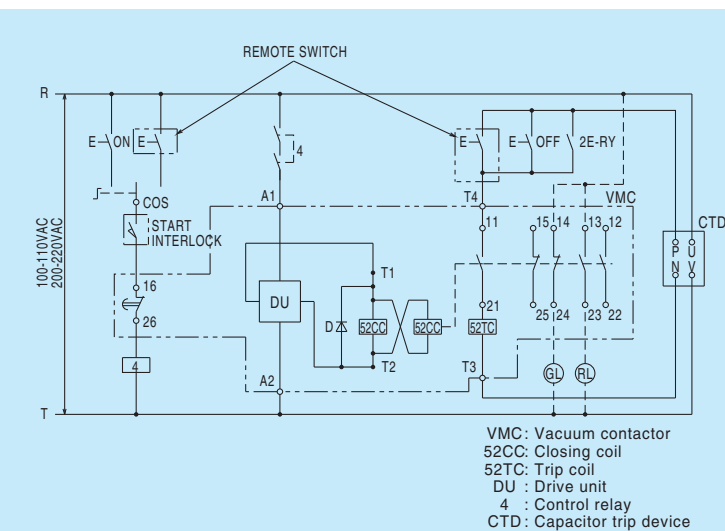

Fig. 12 Latched type operating circuit (Capacitor trip)

12/15kV 400A 5.0/4.0kA Vacuum Contactors

OUTLINE DIMENSIONS

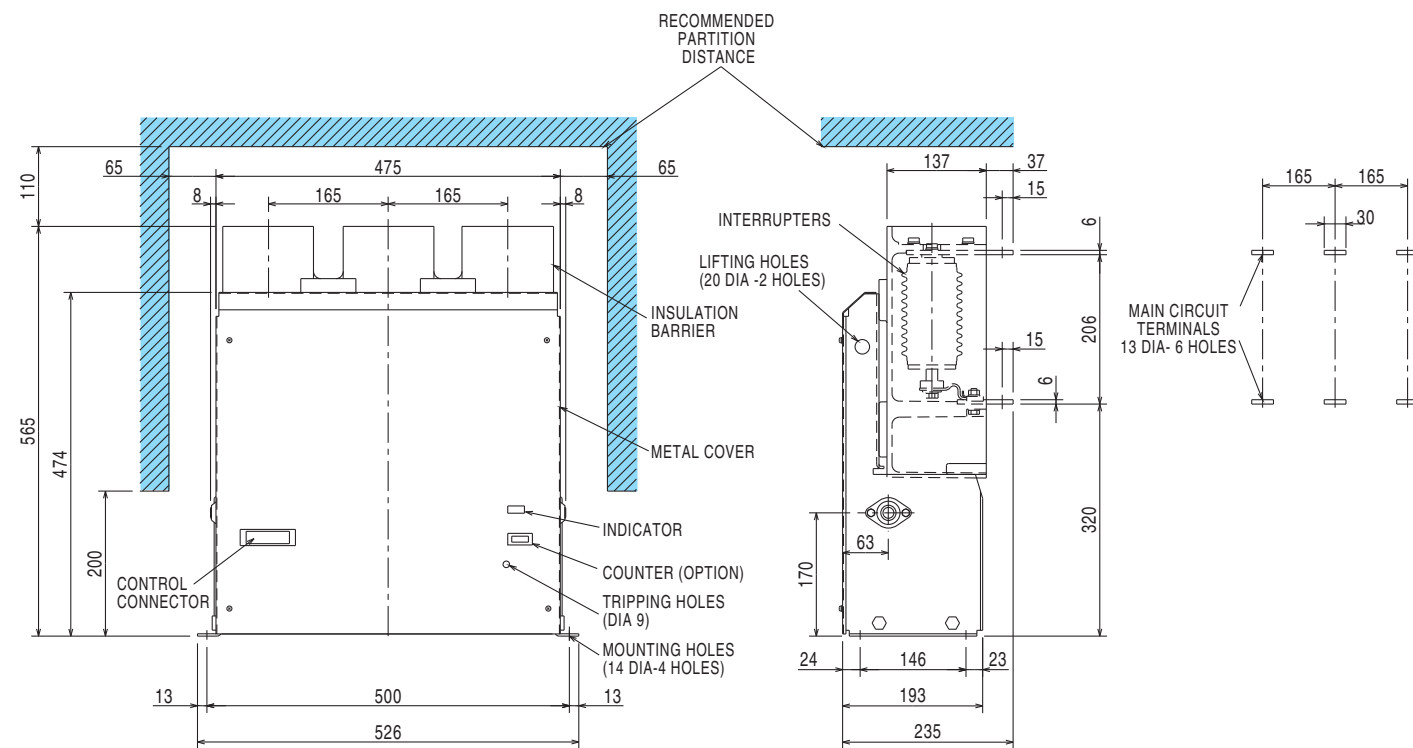

Fig. 13 Types CV-10HA(L)/CV-10HB(L)

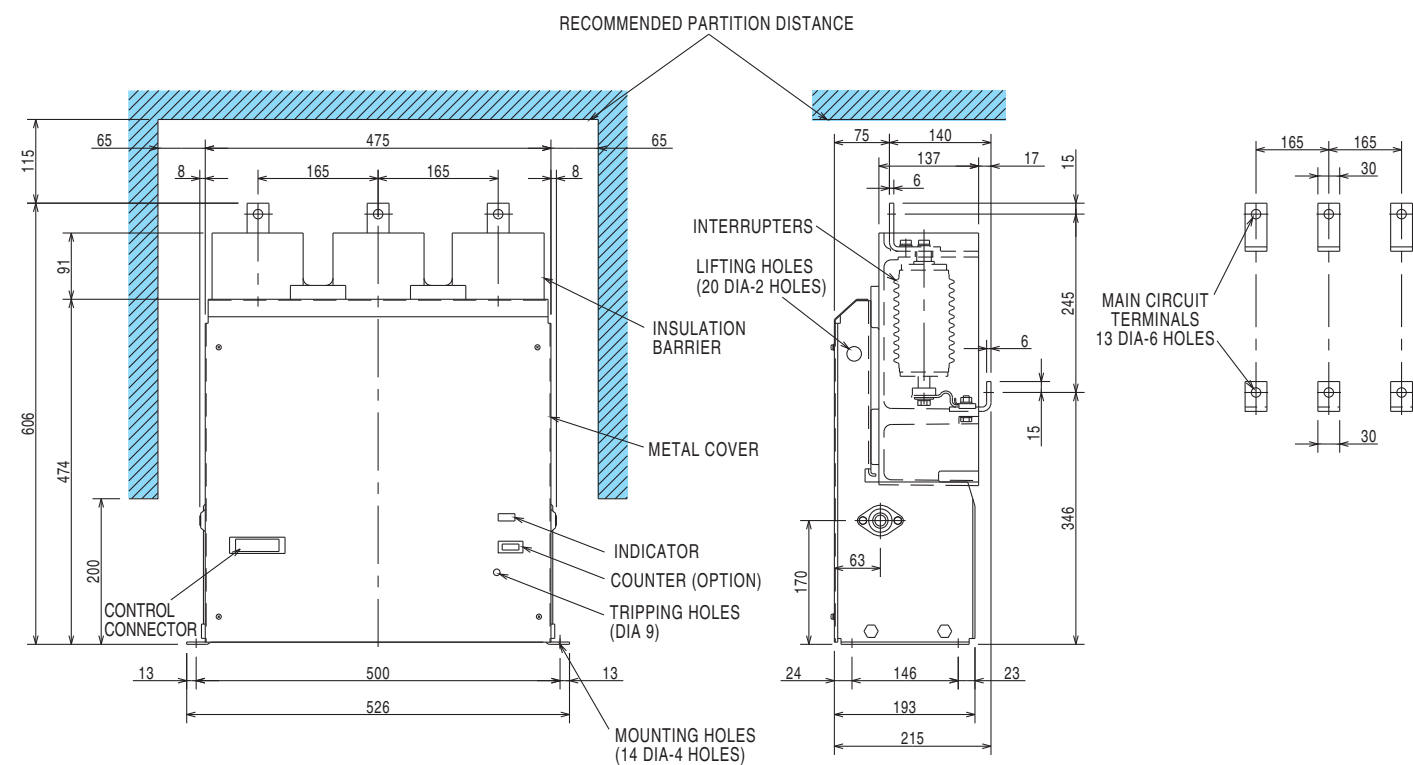

Fig. 14 Types CV-10HA(L)-1/CV-10HB(L)-1

OPERATING CIRCUITS

Non-Latched type High-Voltage Vacuum Contactors

The typical operating circuit is shown in Fig. 15 indicating type CV-10HA/10HB contactor. Make sure to use the "NO" contacts of quick operating relay (4) self-holding circuit. Do not use the "NO" auxiliary contacts of vacuum contactor, this may cause the welding of main contacts when the start (ON) button is pushed incompletely. (refer to the marked 1 in figure)

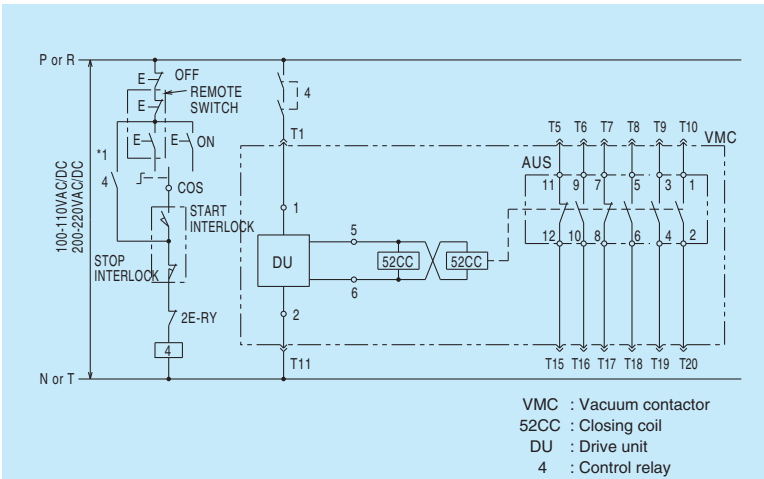

Fig. 15 Non-Latched type operating circuit

Latched type High-Voltage Vacuum Contactors

The typical operating circuits are shown in Fig. 16 and Fig. 17 specifying type CV-10HAL/10HBL contactor. The electrical trip free circuit must be furnished in control circuit. (outside of contactor) A stable DC power source such as battery is recommended for control circuit. If the DC power source is not available, employ the AC closing and capacitor trip device (CTD) for tripping. Make sure to use the "NO" auxiliary contacts (1-2 and 3-4) of vacuum contactor in trip circuit (connected in contactor), and "NC" auxiliary contacts (11-12) of vacuum contactor for control relay circuit.

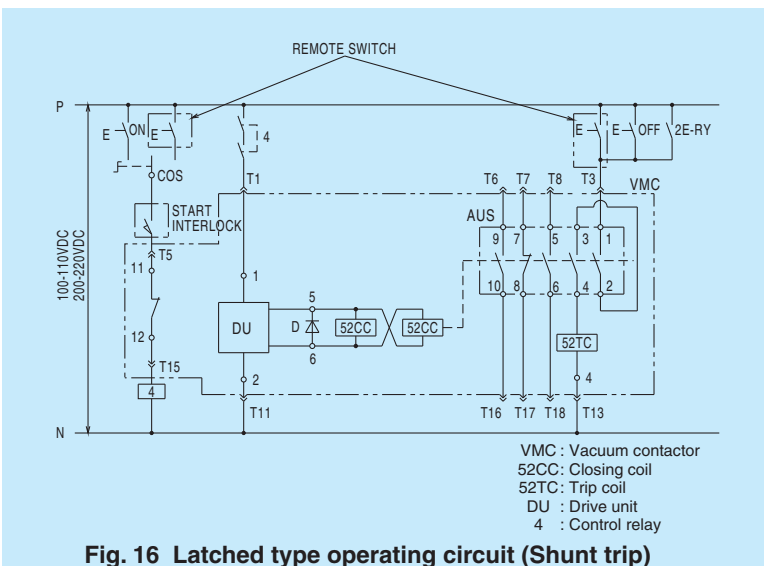

Fig. 16 Latched type operating circuit (Shunt trip)

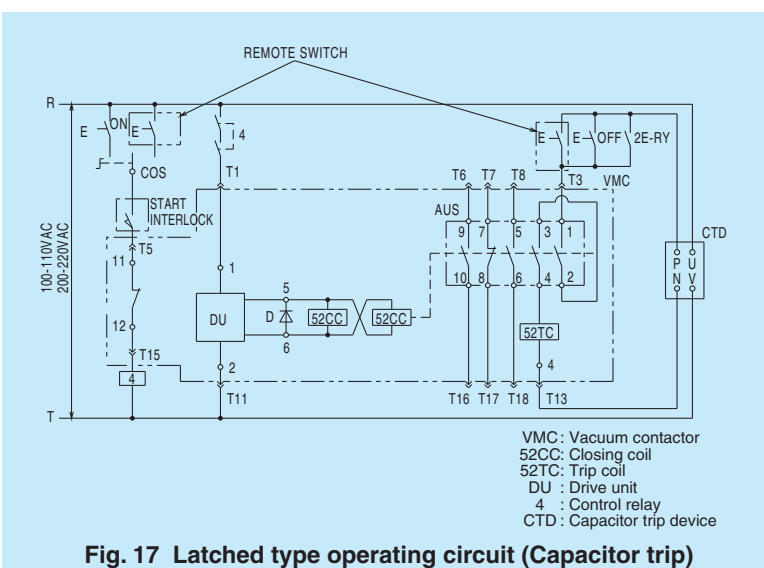

Fig. 17 Latched type operating circuit (Capacitor trip)

APPLICATION AND SELECTION

OPERATING COIL EXCITATION

Non-Latched
(Continuous Excitation)

Mainly applied to frequent switching operation such as motor.

Latched
(Instantaneous Excitation)

Mainly applied to non-frequent switching operation and/or to the important load which require to be contact closed even by power loss.

PROTECTION COORDINATION

The protection coordination with upper/lower stream relay shall be evaluated by considering total system and load characteristics.

The single-phase protection shall be performed which may be occurred by power fuses.

(Apply 2E-relay or fuse blown detection which is provided on combination unit as standard.)

APPLICATION GUIDE TO SURGE

No surge protection is required except for special application, however the insulation coordination shall be evaluated by following table.

Load	Protection	Notice
Rotating Machine	Not required	<ul style="list-style-type: none"> ●The surge suppressor shall be installed for machine rated at 55kW or below, and/or be subject to inching operation. ●The surge suppressor shall be installed between starting contactor and autotransformer for machine started by autotransformer. ●The suppressor shall be installed for machine which has inferior insulation.
Dry-type Transformer	Not required	The surge arrester shall be installed for transformer rated at 150kVA or below and exciting inrush is interrupted.
Oil-immersed Transformer	Not required	The installation of suppressor and insulation coordination shall be evaluated when the low surge level apparatus are connected on secondary circuit of transformer.
Capacitor	Not required	Refer to the clause for capacitor application.

●The surge suppressor is composed of capacitor and series resistor, and is one of the most excellent protection mediums. The device features suppression as well as a decrease of surge generation. Particularly being free from limitation on the number of operating times, this device is suitable for protecting motors and transformer required performing frequent operations.

●The surge arrester has no effect of suppressing the surge generation, this suppresses overvoltage to within a fixed level.

CONTROL TRANSFORMER

The contactor can be operated with following burden of control transformer.

Type Form (Contactor)	Control Transformer	VT
CV-6GA(L), 6HA(L)	400VA or more	100VA 10P10
CV-6KA(L)1	600VA or more	
CV-10HA(L), 10HB(L)	500VA or more	

NOTICE FOR APPLICATION

CAPACITOR APPLICATION

● The current limiting fuses shall be combined for capacitor switching application.

● The series reactor shall be connected, especially back-to-back application.

● Service life of capacitor switching

The switching, opening and closing, of capacitor produces severe condition for contactor, such as high frequency inrush current and interpole recovery voltage higher than twice of normal voltage.

The criteria of maximum number of capacitor switching are shown in the figure below. The vacuum interrupters should be replaced when the number of switching operations reached to point shown in figure.

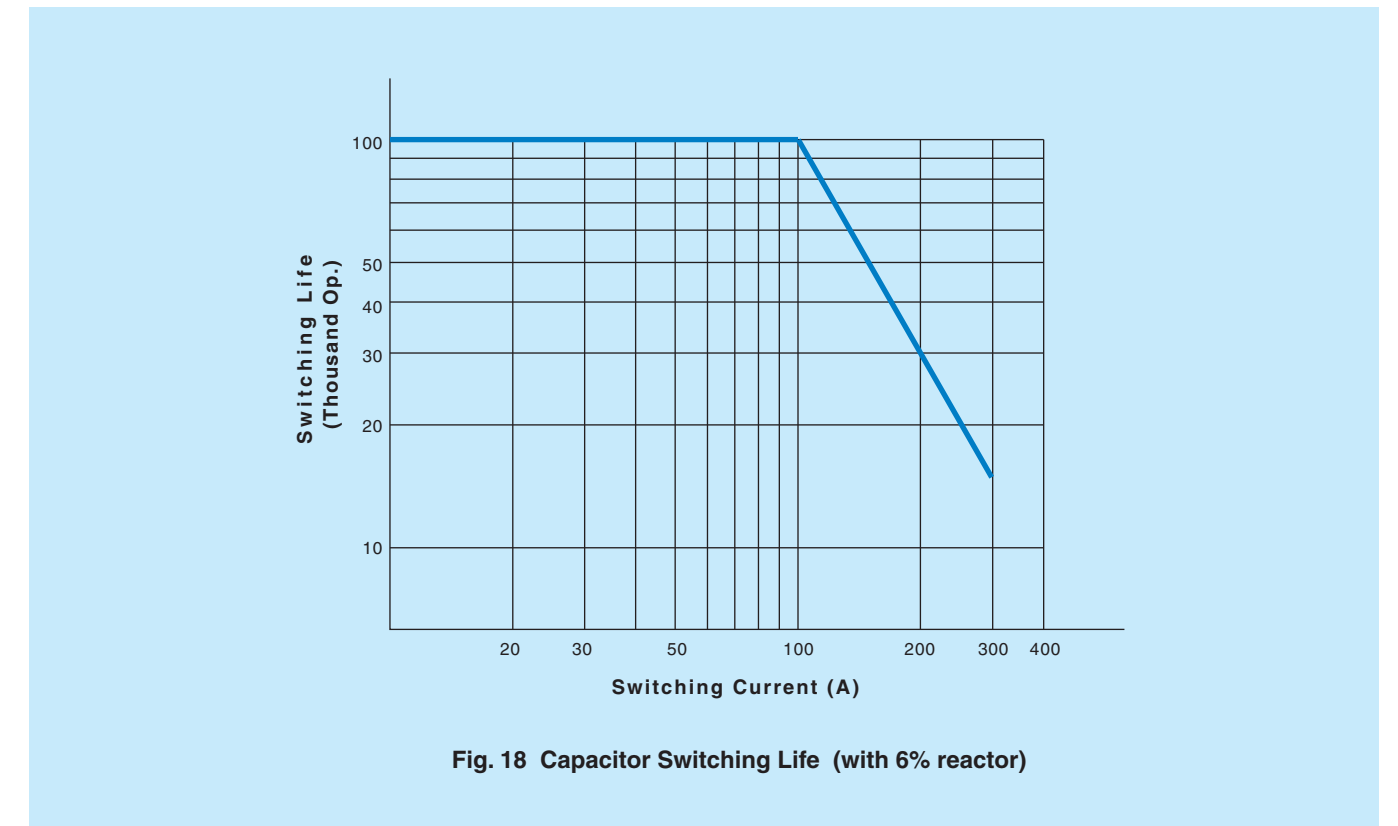

Fig. 18 Capacitor Switching Life (with 6% reactor)

Ordering Information

Non-Latched Type Vacuum Contactor

1. Type-Form CV-□□□□
2. Quantity Set(s)
3. Ratings
Voltage(U_r) kV
Current (I_e) A
Short-circuit Making & Breaking Current kA
4. Operating voltage VDC or AC
5. Options, Accessories, Spare Parts
6. Special Operating Condition

Latched Type Vacuum Contactor

1. Type-Form CV-□□□□
2. Quantity Set(s)
3. Ratings
Voltage(U_r) kV
Current (I_e) A
Short-circuit Making & Breaking Current kA
4. Operating voltage
Closing VDC or AC
Tripping VDC
5. Options, Accessories, Spare Parts
6. Special Operating Condition