

TOSVERT VF-AS1/PS1





PB unit Option
(PB7-4200K / 4400K)
Instruction Manual

I . Safety precautions





The items described in these instructions and on the inverter itself are very important so that you can use the inverter safely prevent injury to yourself and other people around you as well as prevent damage to property in the area.

Thoroughly familiarize yourself with safety precautions and etc. on the instruction manual of the VF-AS1/PS1, and then continue to read the manual. Make sure that you observe all warnings given.

■ General Operation

 Danger	
 Disassembly prohibited	<ul style="list-style-type: none"> ▼ Never disassemble, modify or repair. This can result in electric shock, fire and injury. For repairs, call your sales agency.
 Prohibited	<ul style="list-style-type: none"> ▼ Never remove the front cover when power is on or open door if enclosed in a cabinet. The unit contains many high voltage parts and contact with them will result in electric shock. ▼ Don't stick your fingers into openings such as cable wiring hole and cooling fan covers. This can result in electric shock or other injury. ▼ Don't place or insert any kind of object into the inverter (electrical wire cuttings, rods, wires). This can result in electric shock or fire. ▼ Do not allow water or any other fluid to come in contact with the inverter. This can result in electric shock or fire.
 Mandatory	<ul style="list-style-type: none"> ▼ Wiring must be done after turning off all input power to the VF-AS1/PS1. ▼ If the inverter begins to emit smoke or an unusual odor, or unusual sounds, immediately turn power off. If the equipment is continued to operate in such a state, the result may be fire. Call your local sales agency for repairs.

■ Transportation & installation

 Danger	
 Prohibited	<ul style="list-style-type: none"> ▼ Do not install or operate the inverter if it is damaged or any component is missing. This can result in electric shock or fire. Please consult your local sales agency for repairs. ▼ Do not place any inflammable objects nearby. If a flame is emitted due to malfunction, it may result in a fire. ▼ Do not install in any location where the inverter could come into contact with water or other fluids. This can result in electric shock or fire.
 Mandatory	<ul style="list-style-type: none"> ▼ Must be used in the environmental conditions prescribed in the instruction manual. Use under any other conditions may result in malfunction.
 Warning	
 Prohibited	<ul style="list-style-type: none"> ▼ Do not install in any area where the unit would be subject to large amounts of vibration. That could result in the unit falling, resulting in injury.

■ Wiring

Danger

 Mandatory	<ul style="list-style-type: none"> ▼ The following steps must be performed before wiring. <ol style="list-style-type: none"> (1) Turn off all input power to the inverter. (2) Wait at least 15 minutes and check to make sure that the charge lamp of the VF-AS1/PS1 is no longer lit. (3) Use a tester that can measure DC voltage 800VDC or more, and check to make sure that the voltage to the DC main circuits (between PA and PC) is 45V or less. <p>If these steps are not properly performed, the wiring will cause electric shock.</p> ▼ Tighten the screws on the terminal board to specified torque. If the screws are not tightened to the specified torque, it may lead to fire.
--	--

■ Operations

Danger

 Prohibited	<ul style="list-style-type: none"> ▼ Do not touch inverter and option unit terminals when electrical power is applied to the inverter even if the motor is stopped. Touching the inverter terminals while power is connected to it may result in electric shock. ▼ Do not touch switches when hands are wet and do not try to clean the inverter with a damp cloth. Such practices may result in electric shock. ▼ Do not pull the cable. This can result in damage or malfunction.
---	--

■ Disposal

Warning

 Mandatory	<ul style="list-style-type: none"> ▼ If you throw away this product, have it done by a specialist in industry waste disposal*. If the collection, transport and disposal of industrial waste is done by someone who is not licensed for that job, it is a punishable violation of the law. (Laws in regard to cleaning and processing of waste materials) (*)Persons who specialize in the processing of waste and known as “industrial waste product collectors and transporters” or “industrial waste disposal persons”.
---	--

II . Introduction

Thank you for your purchase of the PB unit option (called the PB unit after this) for the inverter “TOSVERT VF-AS1/PS1”.

This PB unit is the separate dynamic braking unit to use with the inverter “TOSVERT VF-AS1/PS1”.

Before using the PB unit, read this manual and refer to the instruction manual of the pairing inverter, after that use it appropriately.

- Contents -

I. Safety precautions	1
II. Introduction	3
1. Read first	5
2. Names, specifications and dimensions	6
3. Standard connections	8
4. Installation	9
5. Set parameters	13
6. Replacement of expendable parts	14
7. Warranty	14

1. Read first

■ Check product purchase

Before using the product you have purchased, check to make sure that it is exactly what you ordered.

[Check the accessories]

This PB unit option is composed of PB unit and following accessories.





Unpack a parcel and check to make sure the contents.

- Instruction manual : This manual
- bus bars for connecting the BU terminals : parts (B) in this manual 10 and 12 page
- cover of DC choke chassis : parts (E) in this manual 11 page (PB7-4200K only)

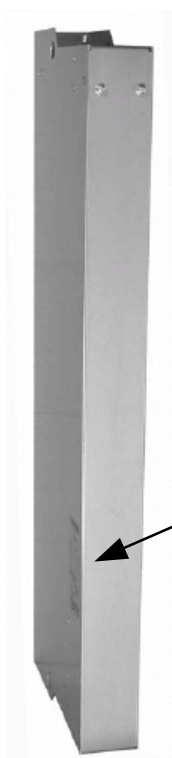
[Check the name plate]

The name plate is put on the left-hand side of the PB unit on the position of figure below.



TOSHIBA Braking Unit		
PB7-4200K		
Input Voltage (V DC)	400...850	 M10 24 Nm/ 212 lb-in
Trigger Voltage (V DC)	785	
P max. (kW)	420	
P cont. (kW)	200	
R min. (Ω)	1.0	
 Serial No. 4617090014280001		Made in Austria
 LISTED 51CA POW/CONVEQ		
TSIJ		

PB unit Type
 Input Voltage (DC)
 threshold Voltage
 Maximum braking power
 Maximum continuous power
 Minimum allowable resistance
 Serial No.

Name plate

[Contents of the product]

Explanation of the type and form written on the label.

P	B	7	-	4	2	0	0	K
Model name				Voltage class		Regenerative braking capacity		

2. Names, specifications and dimensions

■ Specifications

PB unit type	PB7-4200K	PB7-4400K
threshold voltage	785V \pm 1%	
Maximum DC bus voltage	850V	
Maximum braking power at 785V DC	420kW	750kW
Maximum continuous power	200kW	400kW
% ED	5% - 420kW	5% - 750kW
	15% - 320kW	15% - 550kW
	50% - 250kW	50% - 440kW
cycle time	240 second or less	
continuable operating pattern (ex 50% - 250kW, and 50% - 440kW)		
Protective function (note1)	overheat protection, overcurrent protection, overheat protection for AC fan (PB7-4400K only)	
Minimum allowable resistance	1.0 Ω	0.7 Ω
Ambient temperature	-10 to +50 $^{\circ}$ C	
Storage temperature	-25 to +70 $^{\circ}$ C	
Relative humidity	20 to 93 % (free from condensation)	
Vibration	5.9m/s ² {0.6G} or less (10 to 55Hz) (Compliant with JIS C60068-2-6)	
Protective method	IP00 Open type	
Calorific values	550W	1050W
Forced ventilation	190m ³ /h	360m ³ /h
Color	RAL9006 (German standard)	RAL7016 (German standard)
Installation position	mount closely on the left-hand side of the inverter	mount on the left-hand side of the inverter

note1) When each protective functions are detected, the alarm is outputted from the inverter main unit.

■ Outline drawing

VFAS1-4200KPC ~4280KPC/
(VFPS1-4250KPC~4135KPC)
+ DCL1-4200K, 4280K
+ PB7-4200K

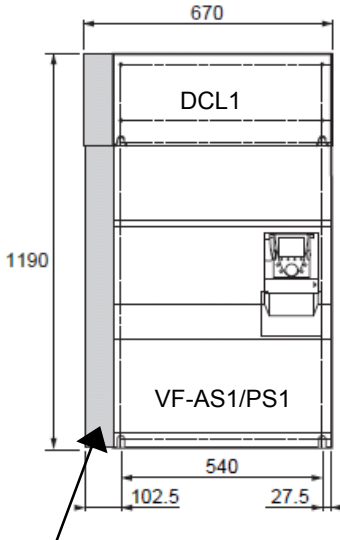

PB7-4200K

VFAS1-4200KPC ~4280KPC/
(VFPS1-4250KPC~4135KPC)
+ PB7-4200K

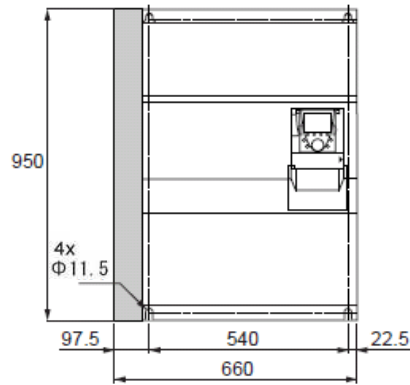

PB7-4400K

note) (1),(2) of below figure are
the dimensions of
(1) with the screws and (2) without the screws

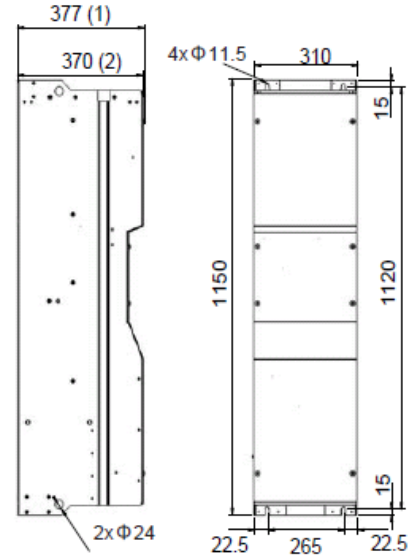

note) PB7-4400K is mechanically mounted on
the wall or the bottom of an enclosure on the left
of the inverter VF-AS1/PS1, and must be placed
110mm (± 5 mm) from the inverter.

■ Selection of braking resistor

Standard braking resistors and recommended wire size are listed in the table below.

	PB7-4200K	PB7-4400K
VFAS1-4200KPC, 4220KPC	Type form : DGP600W-B3 Rating : 8.7kW – 1.9Ω PA, PB terminal : 60mm ²	-
VFAS1-4280KPC VFPS1-4250KPC 4280KPC 4315KPC	Type form : DGP600W-B4 Rating : 14kW – 1.4Ω PA, PB terminal : 60mm ² (PS1-4315KPC : 100 mm ²)	-
VFAS1-4355KPC, 4400KPC VFPS1-4400KPC	-	Type form : DGP600W-B3 ×2 (parallel) Rating : 17.4kW – 0.95Ω PA, PB terminal : 100mm ² G/E terminal : 60mm ²
VFAS1-4500KPC VFPS1-4500KPC 4630KPC	-	Type form : DGP600W-B4 ×2 (parallel) Rating : 28kW – 0.7Ω PA, PB terminal : 150mm ² G/E terminal : 100mm ²

Maximum cable length between the PB unit and the braking resistor is 50m.

Refer to the specifications (page 6 of this manual) about the connectable minimum resistance value of braking resistor.

3. Standard connections

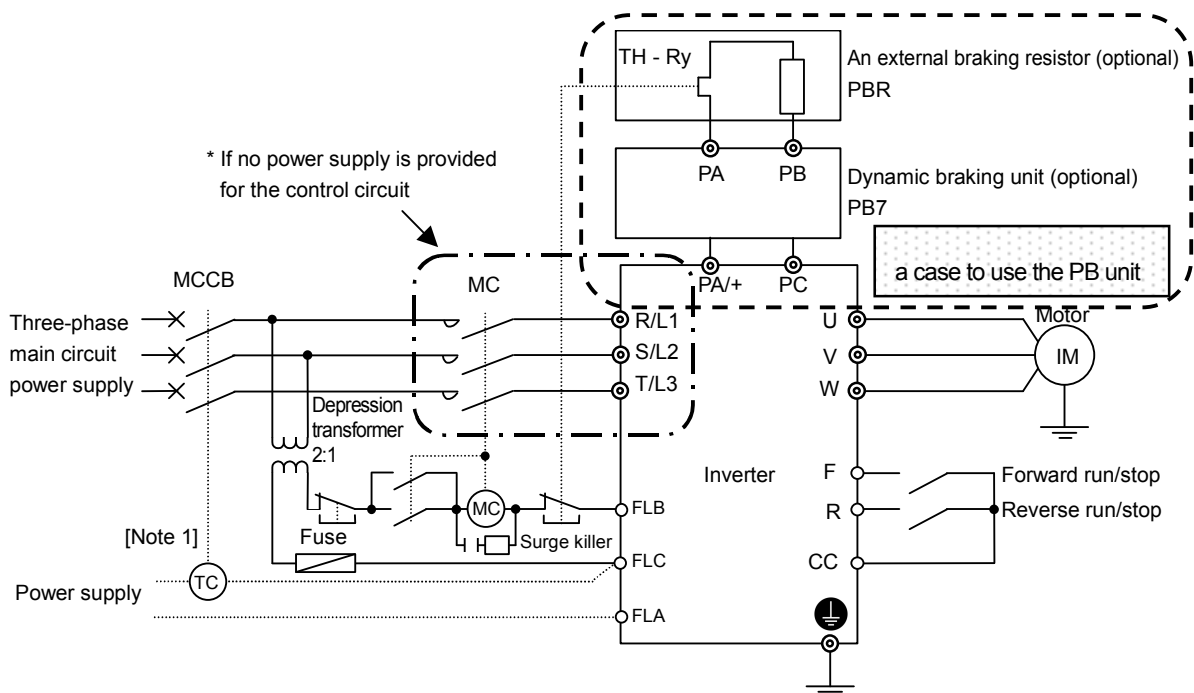

Note 1: Connection when using an MCCB with a top coil instead of an MC.
 Note 2: A depression transformer is required for 400V models but not for 200V models.

[Position of terminals]

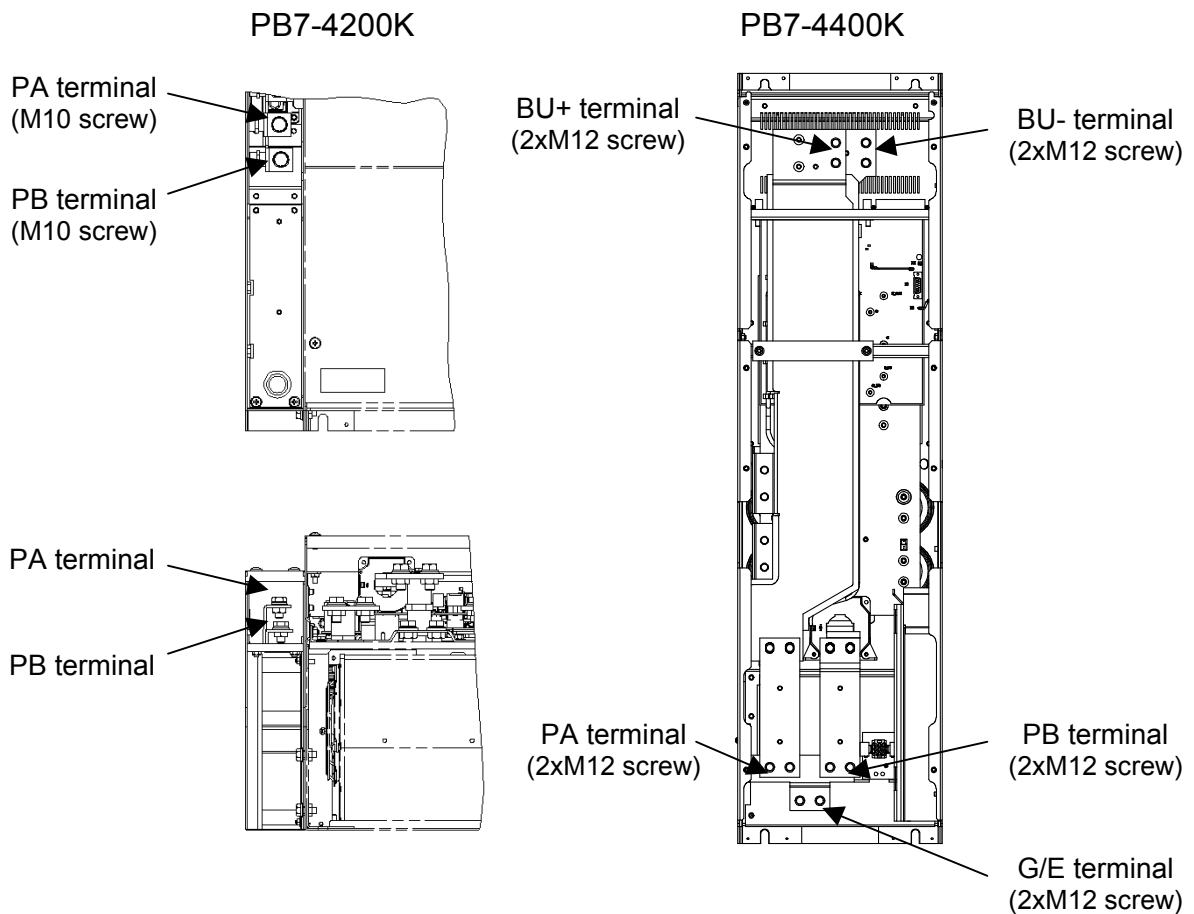

4. Installation

Show below about how to connect between PB7-4200K / PB7-4400K and VF-AS1/PS1, and installation environment.

● Applicable inverter

The PB unit "PB7-4200K" must only be used on VF-AS1 -4200KPC, 4220KPC, 4280KPC and VFPS1-4250KPC, 4280KPC, 4315KPC.

The PB unit "PB7-4400K" must only be used on VF-AS1 -4355KPC, 4400KPC, 4500KPC and VFPS1-4400KPC, 4500KPC, 4630KPC.

PB7-4200K is mechanically mounted on the left-hand side of the inverter VF-AS1/PS1.

PB7-4400K is mechanically mounted on the wall or the bottom of an enclosure on the left of the inverter VF-AS1/PS1, and must be placed 110mm (± 5 mm) from the inverter.

After the mechanical installation of PB unit, connect the bus bars and each cables between the inverter and the PB unit.

■ How to connect between PB7-4200K and VF-AS1/PS1

1. Mechanically install the VF-AS1/PS1.
2. Remove the cover of VF-AS1/PS1 in accordance with the safety instructions given in this document.
3. Detach removable part (A) from the left-hand side of the VF-AS1/PS1.

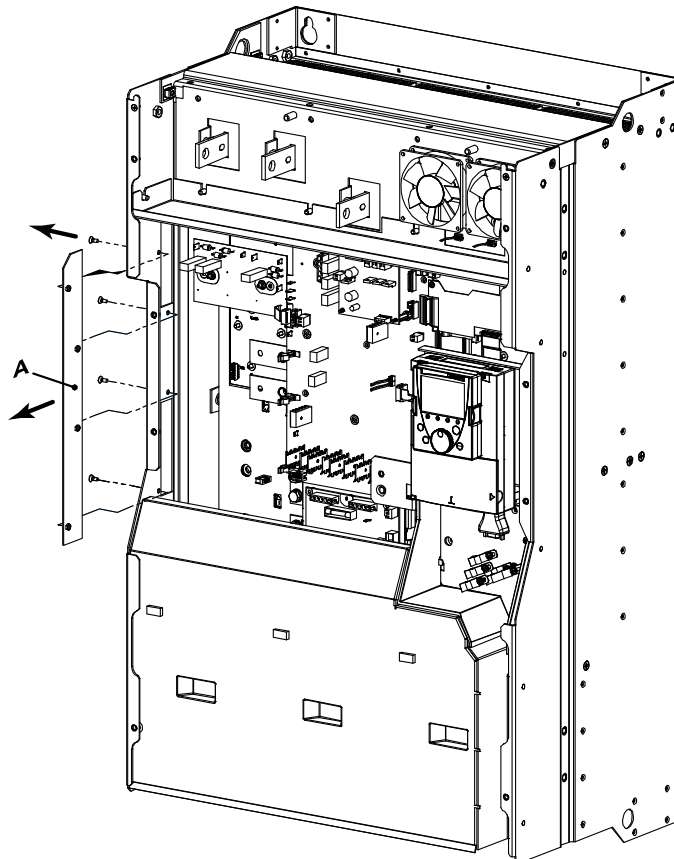

4. Mount the PB7-4200K on the left-hand side of the VF-AS1/PS1.
There are 5 fixing points (5xM8).

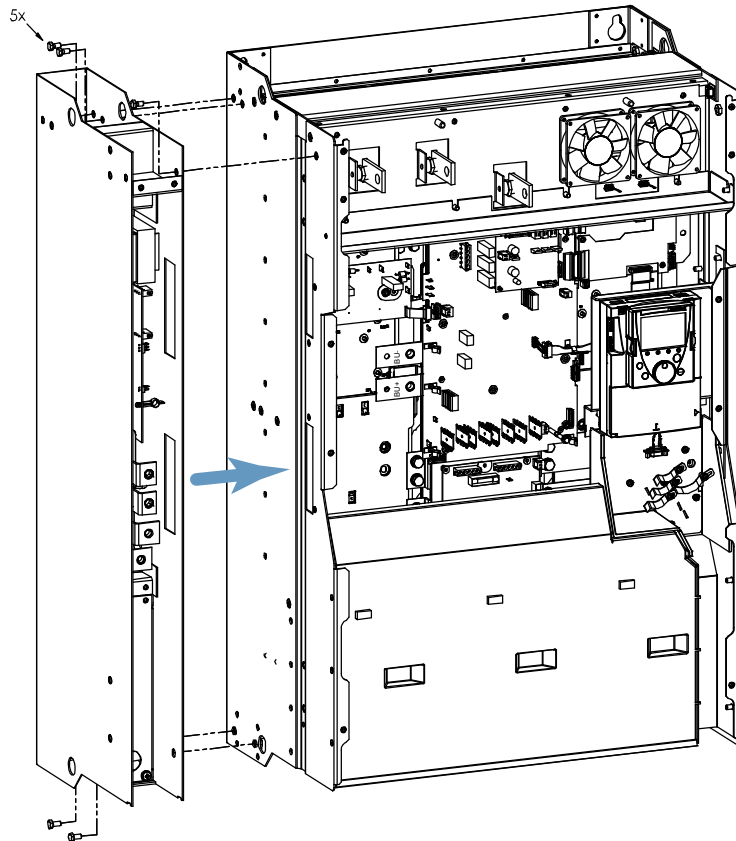

5. Connect the bus bars (B) between terminals BU- and BU+ on the VF-AS1/PS1 and terminals BU- and BU+ on the PB7-4200K.
6. Connect the braking resistor to PA and PB terminals on the PB7-4200K.

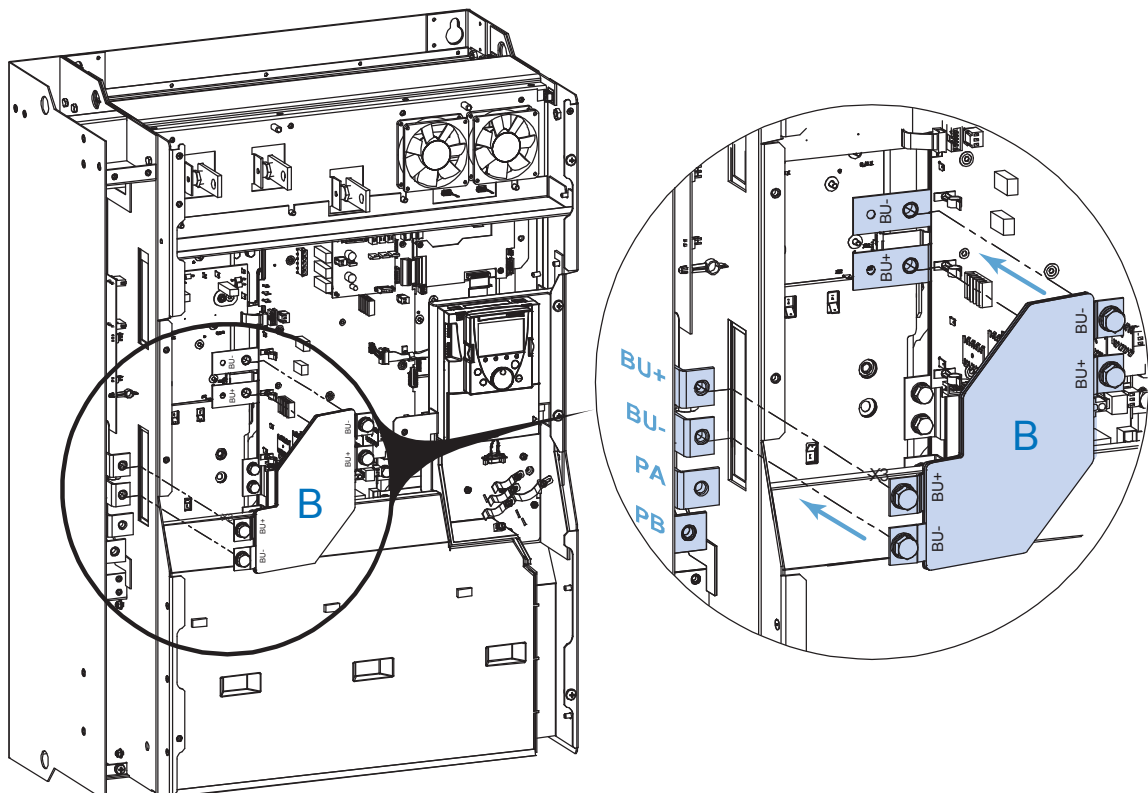

7. Connect the control cables:

- Connect control cable X20 on the PB7-4200K to cable X20 on the VF-AS1/PS1.
- Connect control cable X92 on the PB7-4200K to connector X92 on the VF-AS1/PS1.
- Disconnect cable X3 on the VF-AS1/PS1 from connector X3 on the PCBA of the VF-AS1/PS1.
- Connect disconnected cable X3 to cable X3B on the PB7-4200K.
- Connect cable X3A on the PB7-4200K to connector X3 on the PCBA of the VF-AS1/PS1.

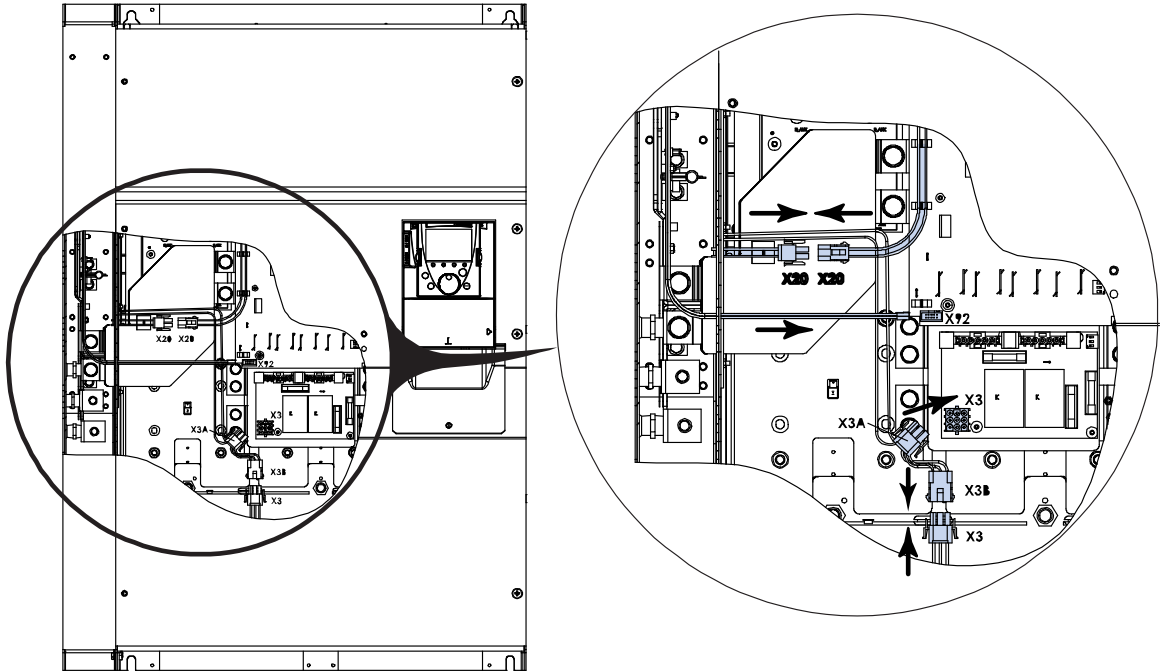

(The following is only a case to use the DC choke option.)

8. Mount the DC choke chassis (C) on the wall or on the bottom of the enclosure.
Refer to the attached installation manual of DC choke option.
9. Detach removable part (D) from DC choke chassis.
10. Mount the PB7-4200K cover (E) on the DC choke chassis.
11. Install the DC chokes in accordance with the installation manual of DC choke option.

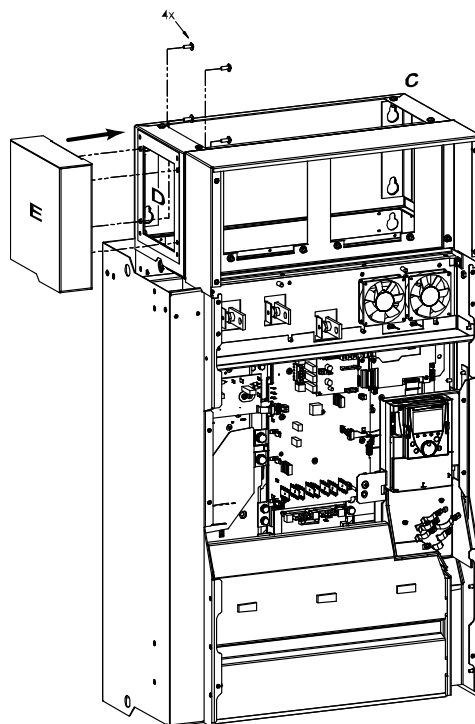

■ How to connect between PB7-4400K and VF-AS1/PS1

1. Mechanically install the VF-AS1/PS1 and the PB7-4400K.
2. Remove the cover of VF-AS1/PS1 in accordance with the safety instructions given in this document.
3. Detach removable part (A) located inside the VF-AS1/PS1.
4. Connect the bus bars (B) between terminals BU- and BU+ on the VF-AS1/PS1 and terminals BU- and BU+ on the PB7-4400K.

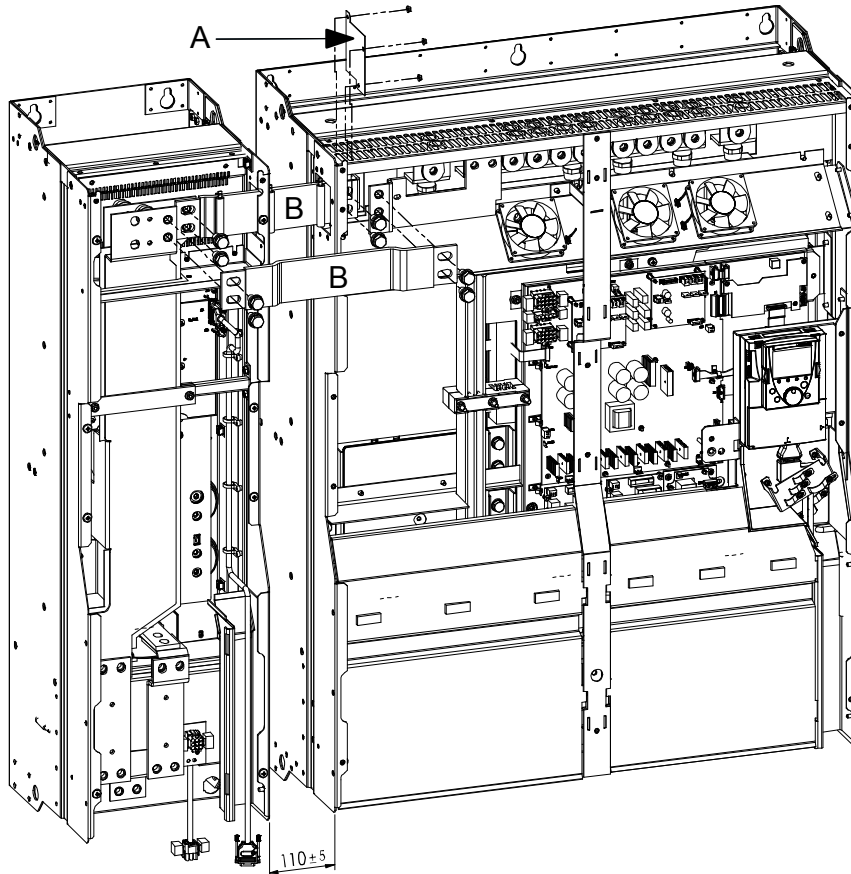

5. Connect the each cables:
 - Connect the X1 control cable from the PB7-4400K to the X1 connector on the VF-AS1/PS1 via the control cable hole.
 - Connect the fan power supply cable from the PB7-4400K to the connector X2 on the VF-AS1/PS1.

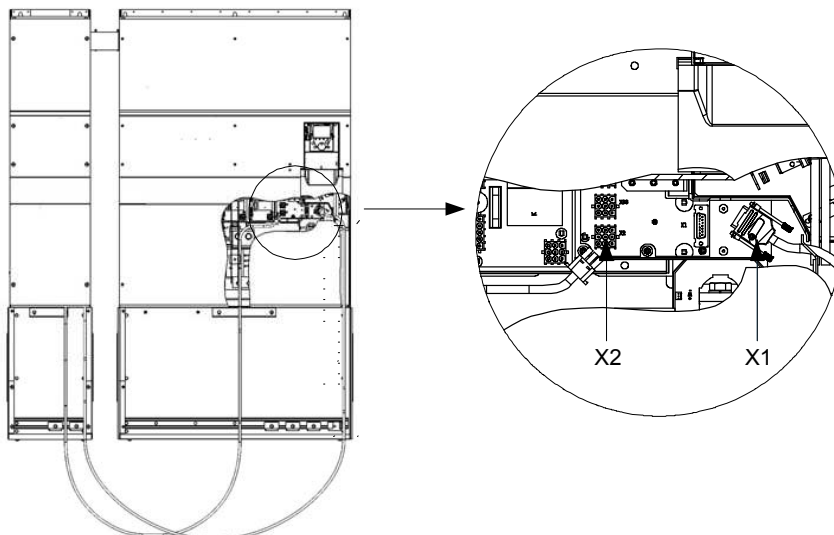

■ Installation environment

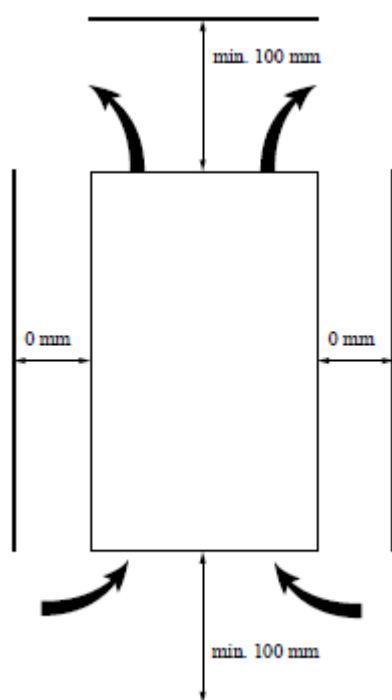

Install the PB unit in a well-ventilated indoor place and mount in portrait orientation. As PB unit uses a built-in cooling fan, at least leave a space of 100mm or more above and below the PB unit.

note) Do not install in any location where there is high humidity or high temperatures and where there are large amounts of dust and metallic fragments. If you are going to install the equipment in any area that presents a potential problem, please consult with your supplier before doing so.

5. Set parameters

Set parameters of the inverter after installation the PB unit. Refer to instruction manual of the VF-AS1 (E6581301 or E6581442) VF-PS1(E6581386) section 5.19 about how to set parameters.

[Parameter setting]

Title	Function	Adjustment range	Default setting
P_b	Dynamic braking selection	0 :Disabled 1 :Enabled (braking resistance overload detect) 2 :Enabled (braking resistance overload not detect)	0
P_{br}	Dynamic braking resistance	$0.5 \sim 1000 \Omega$	According to model
P_{bCP}	Allowable continuous braking resistance	$0.01 \sim 600.0 \text{ kW}$	According to model
$F639$	Braking resistance overload time	$0.1 \sim 600.0 \text{ sec.}$	5.0

P_b is set to 1 or 2 when PB unit is used.
 And set $F305$ (Overvoltage limit operation) to 1 .

6. Replacement of expendable parts

The PB unit is composed of a large number of electronic parts including semiconductor devices. The following parts deteriorate with the passage of time because of their composition or physical properties. The use of aged or deteriorated parts leads to degradation in the performance or a breakdown of the equipment. To avoid such trouble, the PB unit should be checked periodically.

note) Generally, the life of a part depends on the ambient temperature and the conditions of use. The life spans listed below are applicable to parts when used under normal environmental conditions.

1) Cooling fan

The fan, which cools down heat-generating parts, has a service life of about 10 years (average ambient temperature : 40°C, operation time : 12 hours per day). The fan also needs to be replaced if it makes a noise or vibrates abnormally.

2) Smoothing capacitor (PB7-4400K only)

The smoothing aluminum electrolytic capacitor in the main circuit DC section degrades in performance because of ripple current, etc. It becomes necessary to replace the capacitor after it is used for about 5 years under normal conditions (average ambient temperature : 40°C, load factor : not more than 80%, operation time : 12 hours per day).

note) When it becomes necessary to replace expendable parts, contact your supplier. For safety's sake, never replace any part on your own.

7. Warranty

Any part of the PB unit that proves defective will be repaired and adjusted free of charge under the following conditions:

1. Any part of the PB unit which fails or is damaged under normal installation and use within 1 year from the date of delivery shall be repaired free of charge.
2. This warranty applies only to the PB unit option main unit.
3. For the following kinds of failure or damage, the repair cost shall be borne by the customer even within the warranty period.
 - a) Failure or damage caused by improper or incorrect use or handling, or unauthorized repair or modification of the PB unit
 - b) Failure or damage caused by the PB unit falling or an accident during transportation after the purchase
 - c) Failure or damage caused by fire, salty water or wind, corrosive gas, earthquake, storm or flood, lightning, abnormal voltage supply, or other natural disasters
 - d) Failure or damage caused by the use of the PB unit for any purpose or application other than the intended one
4. Unless a service contract is signed beforehand between the customer and Toshiba, in which case the service contract has priority over this warranty.